

Plantation
Verge



**HDB'S SALES LAUNCH
MAY 2023**



BTOgether



PLANTATION VERGE

Plantation Verge is located in Tengah Plantation district and along Plantation Close. The project spans 7 residential blocks ranging from 14 to 18 storeys. There are a total of 971 units of 2-Flexi, 3-, 4-, and 5-room flats available.



The name Plantation Verge references the project's location along the Forest Fringe. The project features a central courtyard that offers various facilities for residents, including children's playgrounds, adult and elderly fitness corners, seats, and shelters where they can relax and interact. The Multi-Storey Car Park (MSCP) comes with a childcare centre on the second storey and a roof garden on the top floor. Please refer to the site plan for the facilities provided in Plantation Verge. Facilities in this project will be accessible by the public.



ABOUT TENGAH TOWN

Homes in Tengah town will be surrounded by lush greenery and nature. HDB has applied its Biophilic Town Framework to guide the enhancement of existing natural assets and the design and development of neighbourhood landscapes in Tengah. Residents can look forward to nature-centric neighbourhoods that offer a greater sense of place, better well-being, and an enhanced quality of life. A variety of outdoor spaces and landscape features will be introduced to draw people closer to nature. A town-wide Active, Beautiful, and Clean Waters design strategy will also be introduced to slow down and treat stormwater runoff, while enhancing the biodiversity. Find out more details on Tengah town at <https://www.hdb.gov.sg/cs/infoweb/about-us/history/hdb-towns-your-home/tengah>.

Tengah will be the first town to integrate housing projects with the area's surrounding greenery and biodiversity. One major attraction will be the approximately 100-metre wide and 5km long Forest Corridor, which will form part of the larger network of greenery that connects the Western Water Catchment Area and the Central Catchment Nature Reserve. In collaboration with the National Parks Boards, various tree species will be planted in the Forest Corridor to transform it into a rich forest habitat.

Complementing the Forest Corridor is the Forest Fringe, a 15- to 20-metre wide linear greenscape that will provide a tranquil and rustic environment for residents to enjoy flora and fauna. In addition, extensive park spaces, such as the Central Park and Community Farmways, will string key amenities and facilities together, providing a safe environment for residents to access their daily amenities.

Tengah will be the first HDB town to have a car-free town centre nestled next to a lush green park. To encourage green commuting, there will be dedicated walking and cycling paths along all roads to create seamless connections within the town. The upcoming Jurong Region Line and bus services will serve the public transport needs of residents.

Tengah is also the first HDB town to be planned with town-wide smart technologies from the outset. Guided by HDB's Smart Town Framework, the various districts will integrate smart technology in its design, so that residents can enjoy a quality living environment. Autonomous vehicles will be piloted in Tengah town to provide convenient first-mile-last-mile connection to key transport nodes and amenities.

Apart from existing primary, secondary, and tertiary institutions in the vicinity of Tengah town, new schools will also be built within the town. This includes Anglo Chinese School (Primary), which will be situated within 1km of Parc Meadow @ Tengah when it relocates to the town in 2030.

Vibrant commercial facilities are planned for the town centre and in the districts, complementing other shopping and dining options in the nearby Bukit Batok town. Check out the heartland shops on Where2Shop@HDB at <https://www.hdb.gov.sg/cs/infoweb/residential/where2shop/explore/bukit-batok>.



ABOUT PLANTATION DISTRICT

Inspired by the villages and farms that once dotted Tengah in the 1950s, Plantation District will be the home of community farming. The Plantation Farmway will run through the precincts, and spaces will be set aside for residents to enjoy community gardening and urban farming in their own neighbourhood. Key amenities such as a Community Club, Neighbourhood Centre, and a shopping street will line the Plantation Farmway, making it a vibrant spot for residents to gather.



IMPORTANT NOTES

HDB precincts are planned to serve the evolving needs of the community. There are spaces catered for future inclusion of amenities/ facilities (such as childcare centres, eldercare facilities, education centres, residents' network centres, day activity centres, etc), commercial facilities (such as shops and eating houses), mechanical and electrical rooms, and such other facilities depending on the prevailing needs. These spaces could be in the void decks, common property, car parks, or stand-alone community buildings.

In addition, housing projects may be located near roads, railways, airbases, and land used for non-residential purposes. Hence, residents may experience higher noise levels. We have provided information on the surrounding land use, proposed facilities and their locations in the maps and plans of individual projects, where feasible. The information provided is indicatively based on the current planning intent of the relevant authorities and is subject to change from time to time.



TENGAH

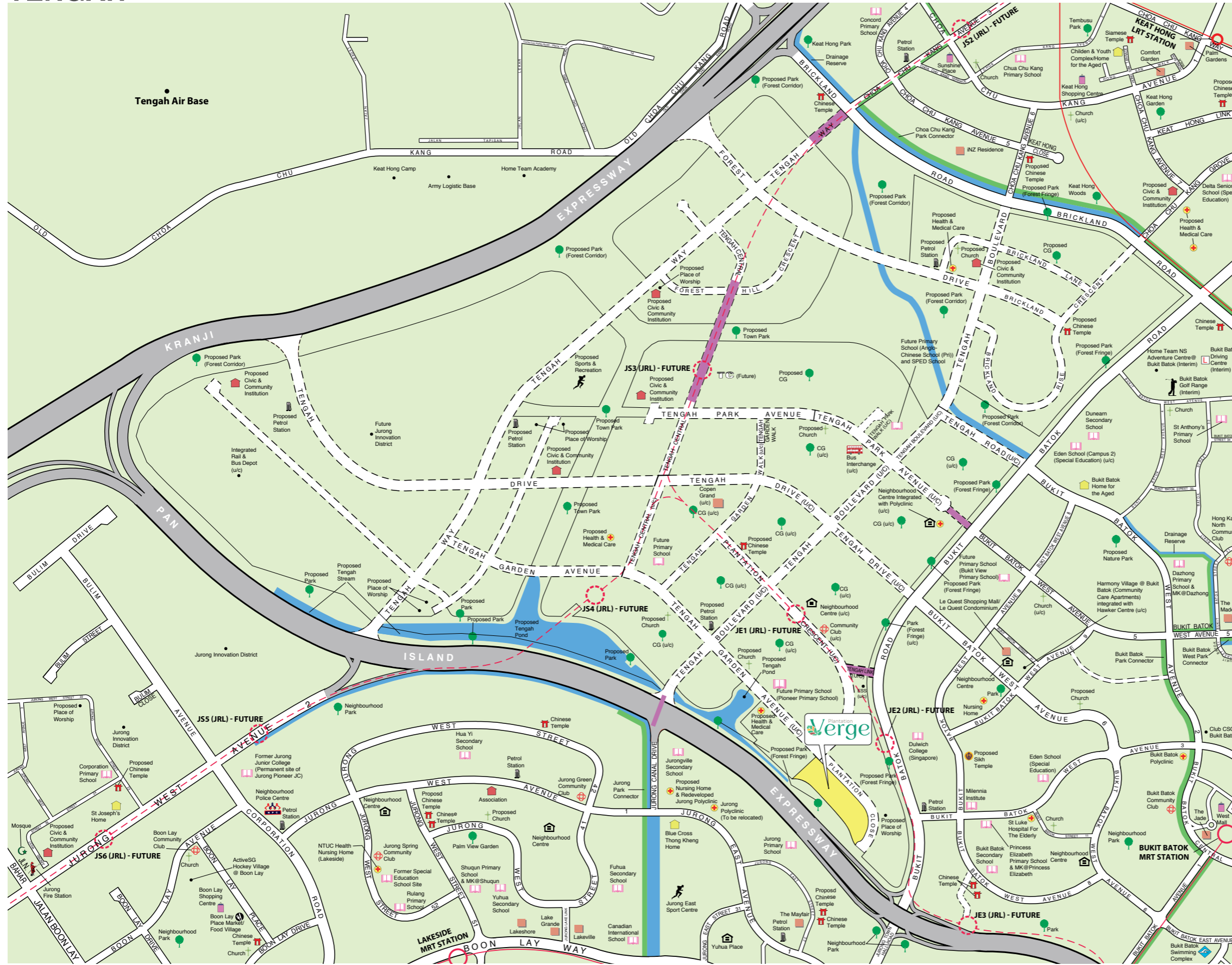

- MRT Line & Station
- Future MRT Line & Station
- LRT Line & Station
- Common Green
- Under Construction/Future Road
- Under Construction
- Electrical Substation
- Future Transit Priority Corridor
- MOE Kindergarten

Notes:

1. All proposed developments and facilities as well as their locations shown are indicative only and are subject to change and planning approval. The implementation of such proposed developments and facilities is subject to review from time to time by the relevant authorities.
2. Proposed Place of Worship includes examples such as Church, Mosque, Chinese Temple, Hindu Temple, etc.
3. Proposed Civic & Community Institution includes examples such as Community Centre/Club, Association, Home for the Aged, etc.
4. Proposed Health & Medical Care includes examples such as Hospitals, Polyclinics, Clinics, Nursing Homes and Eldercare Facilities, etc.
5. The developments and facilities shown (whether existing or proposed) may include other ancillary uses allowed under URA's prevailing Development Control guidelines. Some examples include:
 - (a) Places of Worship (e.g. Chinese Temple or Church) may include columbarium,
 - (b) Community centres may include childcare centres, and schools may be upgraded or built with higher-rise blocks, etc.
6. Transit Priority Corridors (TPCs) are corridors that put together a combination of bus priority solutions to enhance bus priority. Features may include existing measures such as bus lanes or new concepts such as bus-only roads.
7. In view of the COVID-19 situation, temporary COVID-19 related facilities may be set up near residential areas by the relevant authorities.

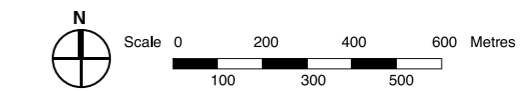

The information contained herein is subject to change at any time without notice and cannot form part of an offer or contract. While reasonable care has been taken in providing this information, HDB shall not be responsible in any way for any damage or loss suffered by any person whether directly or indirectly as a result of reliance on the said information or as a result of any error or omission therein.

ECO-FRIENDLY FEATURES

To encourage green and sustainable living, Plantation Verge will have several eco-friendly features such as:

- Separate chutes for recyclable waste
- Regenerative lifts to reduce energy consumption
- Bicycle stands to encourage cycling as an environmentally-friendly form of transport
- Parking spaces to facilitate future provision of electric vehicle charging stations
- Use of sustainable products in the project
- Active, Beautiful, Clean Waters design features to clean rainwater and beautify the landscapes



SEPARATE CHUTES FOR RECYCLABLE WASTE



BICYCLE STANDS



ABC WATERS DESIGN FEATURES

SMART SOLUTIONS

Plantation Verge will come with the following smart solutions to reduce energy usage, and contribute to a safer and more sustainable living environment:

- Smart-Enabled Homes with provisions to facilitate adoption of smart home solutions
- Smart Lighting in common areas to reduce energy usage
- Smart Pneumatic Waste Conveyance System to optimise the deployment of resources for cleaner and fuss-free waste disposal



EMBRACING WALK CYCLE RIDE

With an increased focus on active and healthy living, Plantation Verge is designed with well-connected pathways to make it easier for residents to walk and cycle more as part of your daily commutes to the surrounding amenities and public transport:

- Convenient access and walking distance to public transport
- Safe, pleasant, and welcoming streets for walking and cycling
- Sheltered covered linkways and barrier free accessibility to facilities
- Wayfinding and signages for orientation and navigation

Plantation Verge residents will be served by the upcoming Jurong Region Line MRT stations and upcoming bus interchange located along Tengah Boulevard. Learn more about transport connectivity in this town using MyTransport. sg app found at <https://www.lta.gov.sg/content/dam/ltagov/Home/PDF/MTM.pdf>.

CENTRALISED COOLING SYSTEM

Residents can choose to subscribe to have air conditioning provided from a centralised cooling system. This system for public housing is the first of its kind in Singapore.

Cooling to each household unit will come from highly energy efficient chillers, and residents need not install nor maintain outdoor condensing units on their air-conditioner ledge. They will get to enjoy cost savings while contributing to a sustainable lifestyle in this eco-friendly district. Residents may decide to subscribe to the centralised cooling system after signing the Agreement for Lease.



CAR-LITE PRECINCT

As announced by LTA and HDB on 5 Oct 2022, there will be designated HDB car-lite precincts within gazetted car-lite areas. They are planned with good public transport, walking, and cycling connections.

Plantation Verge is designated as an HDB car-lite precinct within the Tengah car-lite area. Designed for residents to adopt green modes of commuting, the parking provision will be reduced, freeing up space for public facilities and greenery. With more limited parking provision, available lots will be prioritised for residents in these precincts through additional parking demand management measures:

- **Season parking will be reduced and restricted to residents only.** Similar to all other HDB residential carparks, season parking sales will be on a first-come-first-served basis, subject to availability, and residents' first car will be accorded higher priority than residents' 2nd and subsequent car(s). As non-residents will not be able to buy season parking within car-lite precincts, they may do so at alternative nearby car parks.
- **Residents who buy season parking for their 2nd and subsequent vehicles will be charged a higher season parking rate** pegged to Tier 2 Restricted Zone rate, subject to availability. Learn more about the tiers for monthly season parking charges and the current rates at <https://www.hdb.gov.sg/car-parks/season-parking/season-parking/application-procedure>.
- **Short-term parking for visitors will remain available, albeit with limited lots.** Parking charges may be adjusted based on demand.



FINISHES AND FITTINGS

To boost construction productivity, Plantation Verge will be built using the Prefabricated Prefinished Volumetric Construction (PPVC) method. The flats will come with full floor finishes, internal doors, and sanitary fittings.

2-ROOM FLEXI

Available either on a 99-year lease or short-lease

- Vinyl strip flooring in the:
 - Living/ dining
 - Bedroom
- Floor tiles in the:
 - Bathroom
 - Household shelter
 - Kitchen
- Wall tiles in the:
 - Bathroom
 - Kitchen
- A sliding partition/ door for the bedroom and folding bathroom door
- Sanitary fittings, i.e. wash basin with tap mixer, shower set with bath/ shower mixer, and water closet suite
- Grab bars (for 2-room Flexi flats on short-leases)

3-, 4- AND 5-ROOM

- Vinyl strip flooring in the:
 - Living/ dining
 - Bedroom
- Floor tiles in the:
 - Bathrooms
 - Household shelter
 - Kitchen/ utility (3-room)
 - Kitchen and service yard (4- and 5-room)
- Wall tiles in the:
 - Bathrooms
 - Kitchen/ utility (3-room)
 - Kitchen (4- and 5-room)
- Internal doors for bedrooms and folding doors for bathrooms
- Sanitary fittings, i.e. wash basin with tap mixer, shower set with bath/ shower mixer, and water closet suite

OPTIONAL COMPONENT SCHEME

Elderly buyers of short-lease 2-room Flexi flats can opt in for elderly-friendly and other fittings under the Optional Component Scheme (OCS). Please refer to the attached OCS leaflet for details.

If an elderly buyer opts in for the OCS, the cost of the optional components will be added to the price of the 2-room Flexi flat.

LAYOUT IDEAS

2 ROOM FLEXI (TYPE 1) FLOOR PLAN (With Suggested Furniture Layout)

Approx. Floor Area 40 sqm

Inclusive of Internal Floor Area of 38 sqm and Air-Con Ledge



The coloured floor plan is not intended to demarcate the boundary of the flat

2 ROOM FLEXI (TYPE 2) FLOOR PLAN (With Suggested Furniture Layout)

Approx. Floor Area 48 sqm

Inclusive of Internal Floor Area of 46 sqm and Air-Con Ledge



To meet the different lifestyle needs, the 46sqm 2-room Flexi flats come with a flexible space which flat buyers can use according to their preference. This flexible space can be used for dining, a study or to place an extra bed.

2 ROOM FLEXI (TYPE 2) FLOOR PLAN (With Suggested Furniture Layout)

Approx. Floor Area 48 sqm

Inclusive of Internal Floor Area of 46 sqm and Air-Con Ledge



The coloured floor plan is not intended to demarcate the boundary of the flat

LAYOUT IDEAS

3 ROOM FLOOR PLAN (With Suggested Furniture Layout)

Approx. Floor Area 69 sqm

Inclusive of Internal Floor Area of 66 sqm and Air-Con Ledge



To cater to changing lifestyles and to provide more flexibility in the use of kitchen space, HDB has designed the flats with a combined kitchen/utility space.

The layout offers homeowners flexibility in configuring the area according to their preferences.

For example, you can add a partition to separate the utility from kitchen, as indicated in the dotted lines.

4 ROOM FLOOR PLAN (With Suggested Furniture Layout)

Approx. Floor Area 93 sqm

Inclusive of Internal Floor Area of 90 sqm and Air-Con Ledge



The coloured floor plan is not intended to demarcate the boundary of the flat

5 ROOM FLOOR PLAN (With Suggested Furniture Layout)

Approx. Floor Area 113 sqm

Inclusive of Internal Floor Area of 110 sqm and Air-Con Ledge

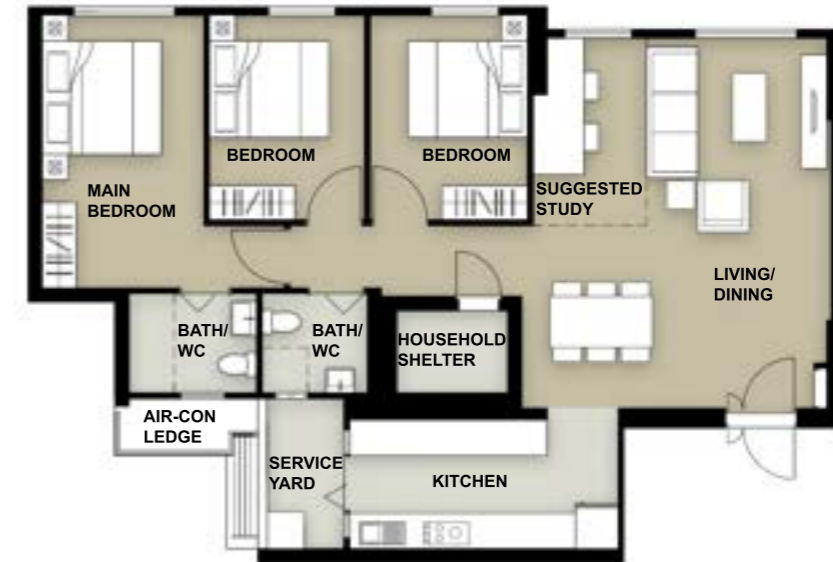

The coloured floor plan is not intended to demarcate the boundary of the flat



Plantation Verge is a car-lite precinct designed for residents to adopt green modes of commuting and to enjoy the benefits of more sustainable car-lite living. Car parking provision will be reduced for this project.

APPLICANTS ARE ENCOURAGED TO VISIT THE PLACE BEFORE BOOKING A FLAT.

Notes:

- All proposed developments and facilities as well as their locations shown are indicative only and are subject to change and planning approval. The implementation of such proposed developments and facilities is subject to review from time to time by the relevant authorities.
- The developments and facilities shown (whether existing or proposed) may include other ancillary uses allowed under URA's prevailing Development Control guidelines. Some examples include:
 - (a) Places of Worship (e.g. Chinese Temple or Church) may include columbarium,
 - (b) Community centres may include childcare centres, and schools may be upgraded or built with higher-rise blocks, etc.
- The use of the void deck in any apartment block, common property (such as precinct pavilion), car park or stand-alone community building for future amenities/facilities (such as childcare centres, eldercare facilities, education centres, residents' network centres and day activity centres), commercial facilities (such as shops and eating houses), mechanical and electrical rooms and such other facilities, is subject to review from time to time.
- The residential blocks may be completed ahead of the proposed precinct facilities, so that flat buyers are able to collect the keys to their new homes earlier.
- Unless otherwise indicated in the sales brochure, all facilities within the project, including but not limited to roof gardens and sky terraces (if any), will be open to the public.
- In view of the COVID-19 situation, temporary COVID-19 related facilities may be set up near residential areas by the relevant authorities.

SITE PLAN

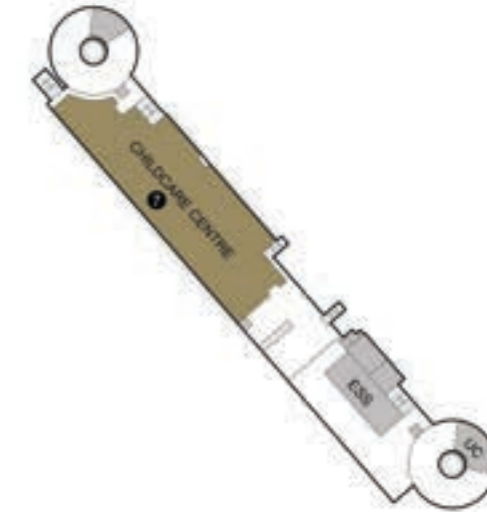

2ND STOREY FLOOR PLAN
BLK 101

FLAT TYPE

2 ROOM FLEXI (TYPE 1)	2 ROOM FLEXI (TYPE 2)	3 ROOM
4 ROOM	5 ROOM	

PLAY FACILITIES

- CHILDREN PLAYGROUND
- ADULT FITNESS STATION
- ELDERLY FITNESS STATION

COMMUNAL AREAS

- PRECINCT PAVILION AT 1ST STOREY
- DROP-OFF PORCH

SOCIAL AMENITIES

- FUTURE AMENITIES / FACILITIES AT 1ST STOREY
- CHILDCARE CENTRE AT 2ND STOREY

OTHERS

LINKWAY	S: SHELTER	AMENITY LOCATED (BELOW)
TRELLIS	ENTRANCE / EXIT FOR CAR PARK	CENTRALISED REFUSE CHUTE/ CHUTE FOR RECYCLABLE WASTE (PNEUMATIC WASTE CONVEYANCE SYSTEM)
SERVICE	ESS: ELECTRICAL SUBSTATION	SERVICE BAY
UC: UTILITY CENTRE	AIR-WELL	WATERBODY

Block Number	Number of Storeys	2-Room Flexi		3 Room	4 Room	5 Room	Total
		Type 1	Type 2				
100A	18	0	0	17	102	34	153
100B	18	0	0	17	85	84	186
101A	14	26	65	13	39	26	169
101B	14	26	65	13	39	26	169
102A	15	0	0	0	56	42	98
102B	15	0	0	14	28	56	98
102C	15	0	0	14	28	56	98
Total		52	130	88	377	324	971

The information contained herein is subject to change at any time without notice and cannot form part of an offer or contract. While reasonable care has been taken in providing this information, HDB shall not be responsible in any way for any damage or loss suffered by any person whether directly or indirectly as a result of reliance on the said information or as a result of any error or omission therein.

UNIT DISTRIBUTION

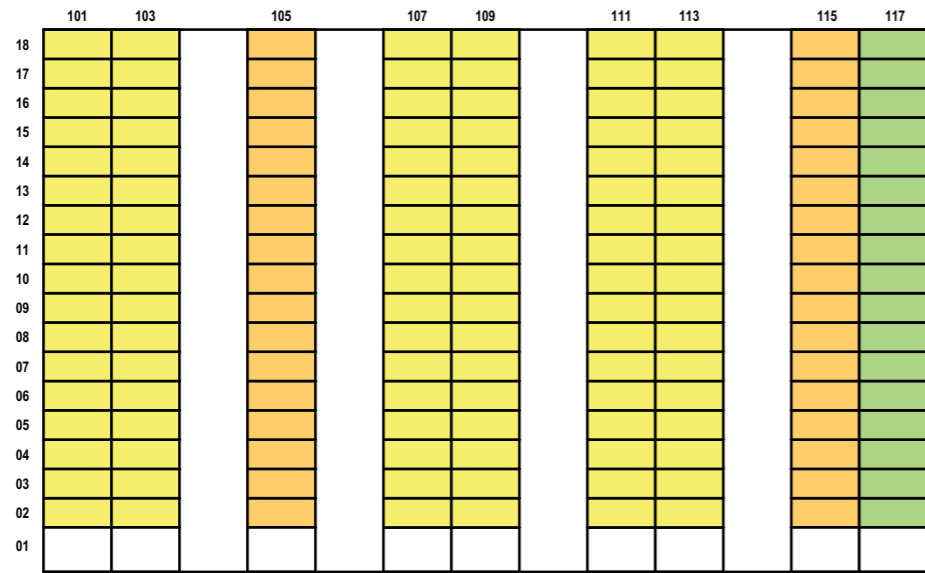
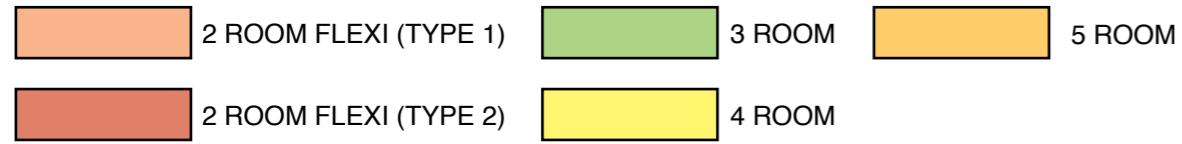

BLOCK 100A

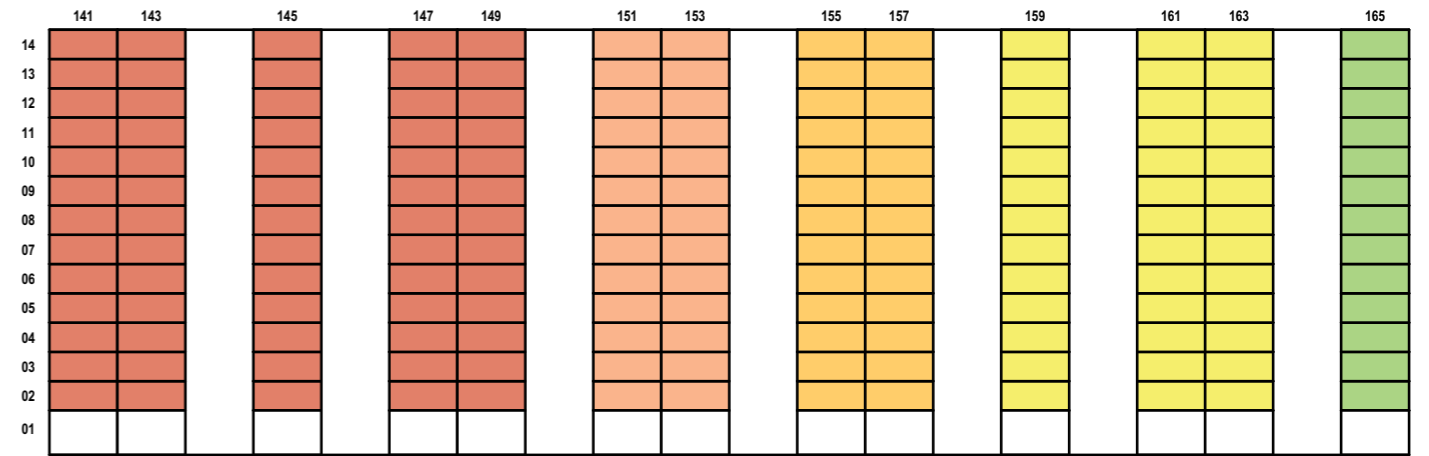

BLOCK 101A

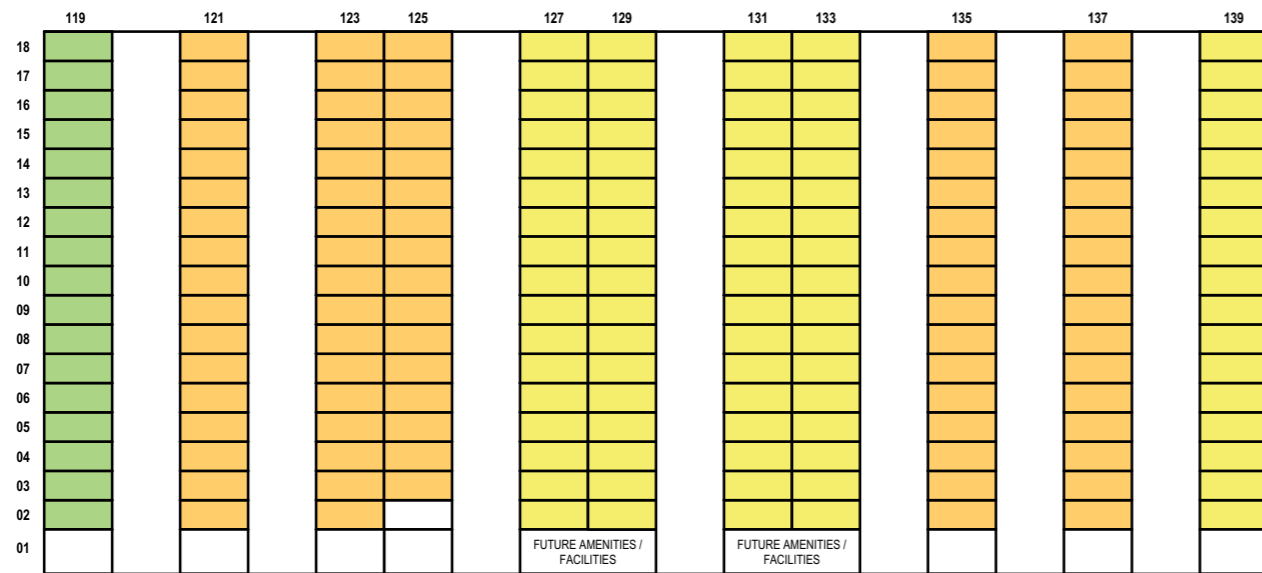

BLOCK 100B

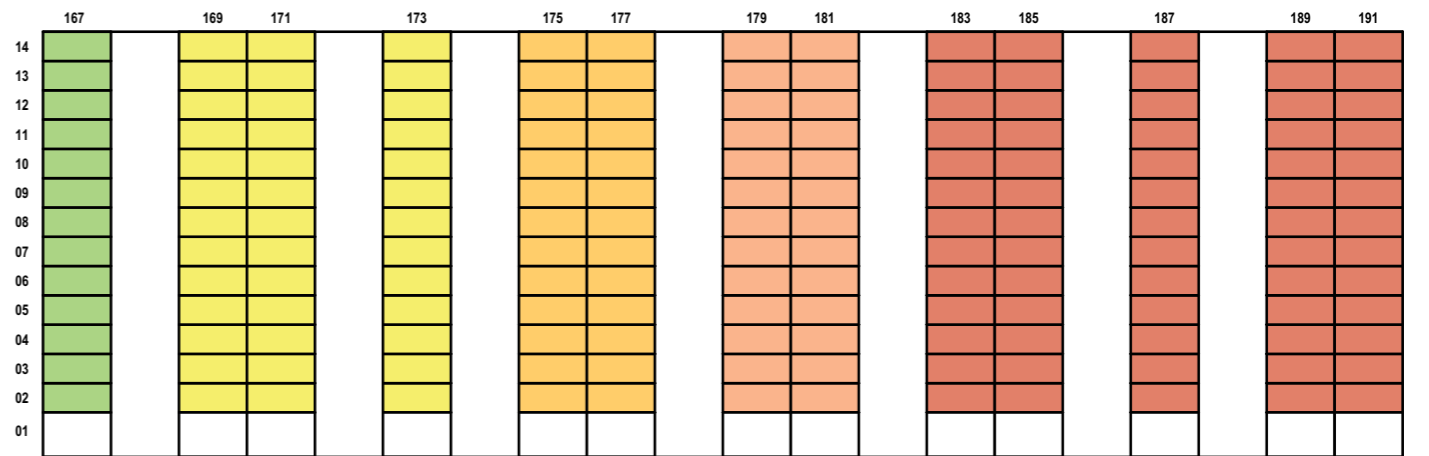

BLOCK 101B

UNIT DISTRIBUTION

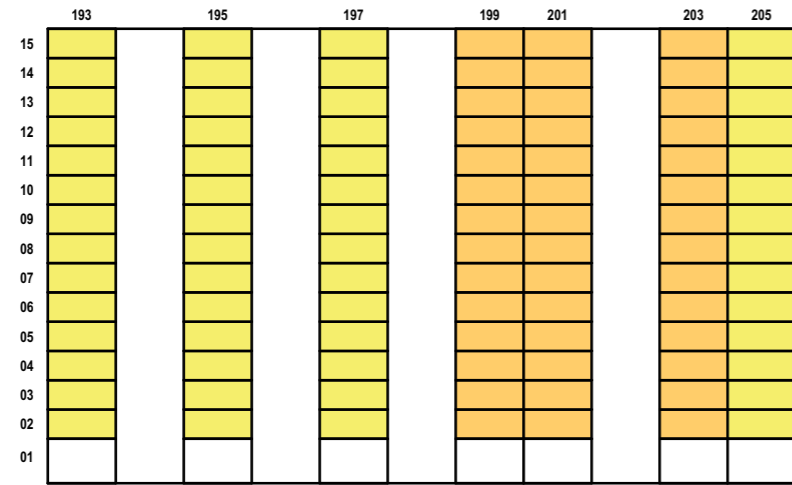
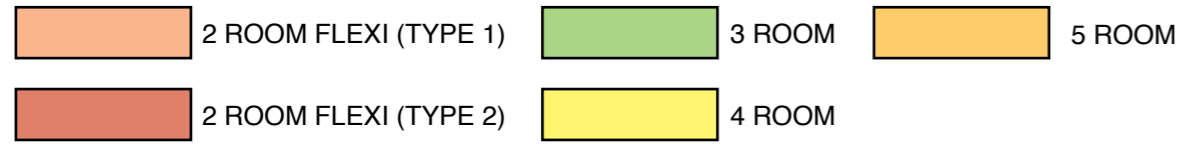

BLOCK 102A

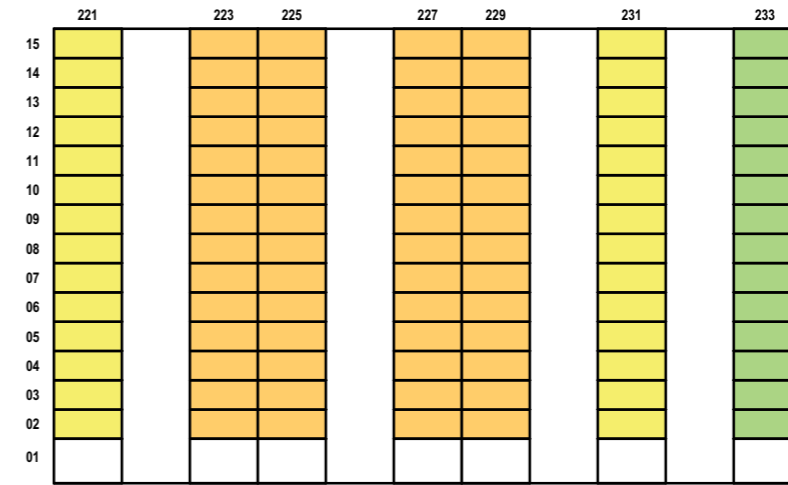

BLOCK 102C

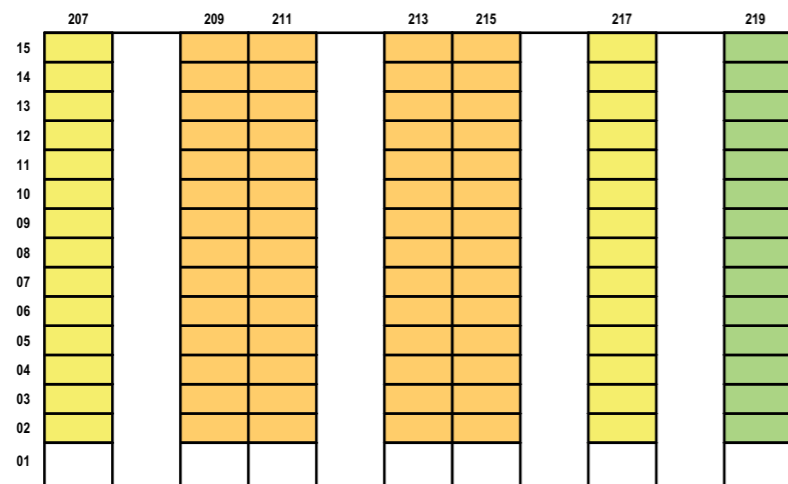

BLOCK 102B



BLOCK 100A | 2ND TO 4TH, 8TH TO 10TH & 14TH TO 16TH STOREY FLOOR PLAN

<p>WINDOW LEGEND:</p>	<p>UNLESS OTHERWISE INDICATED, ALL WINDOWS WILL BE STANDARD HEIGHT WINDOWS</p>	<p>SCALE 0 2 4 6 8 10 METRES</p>	<p>THE COLOURED FLOOR PLAN IS NOT INTENDED TO DEMARCATATE THE BOUNDARY OF THE FLAT</p>
<p>W1 - THREE QUARTER HEIGHT WINDOW (APPROX. 550mm HIGH PARAPET WALL)</p>			



BLOCK 100A | 5TH TO 7TH, 11TH TO 13TH, 17TH & 18TH STOREY FLOOR PLAN

<p>WINDOW LEGEND:</p>	<p>UNLESS OTHERWISE INDICATED, ALL WINDOWS WILL BE STANDARD HEIGHT WINDOWS</p>	<p>SCALE 0 2 4 6 8 10 METRES</p>	<p>THE COLOURED FLOOR PLAN IS NOT INTENDED TO DEMARCATATE THE BOUNDARY OF THE FLAT</p>
<p>W1 - THREE QUARTER HEIGHT WINDOW (APPROX. 550mm HIGH PARAPET WALL)</p>			

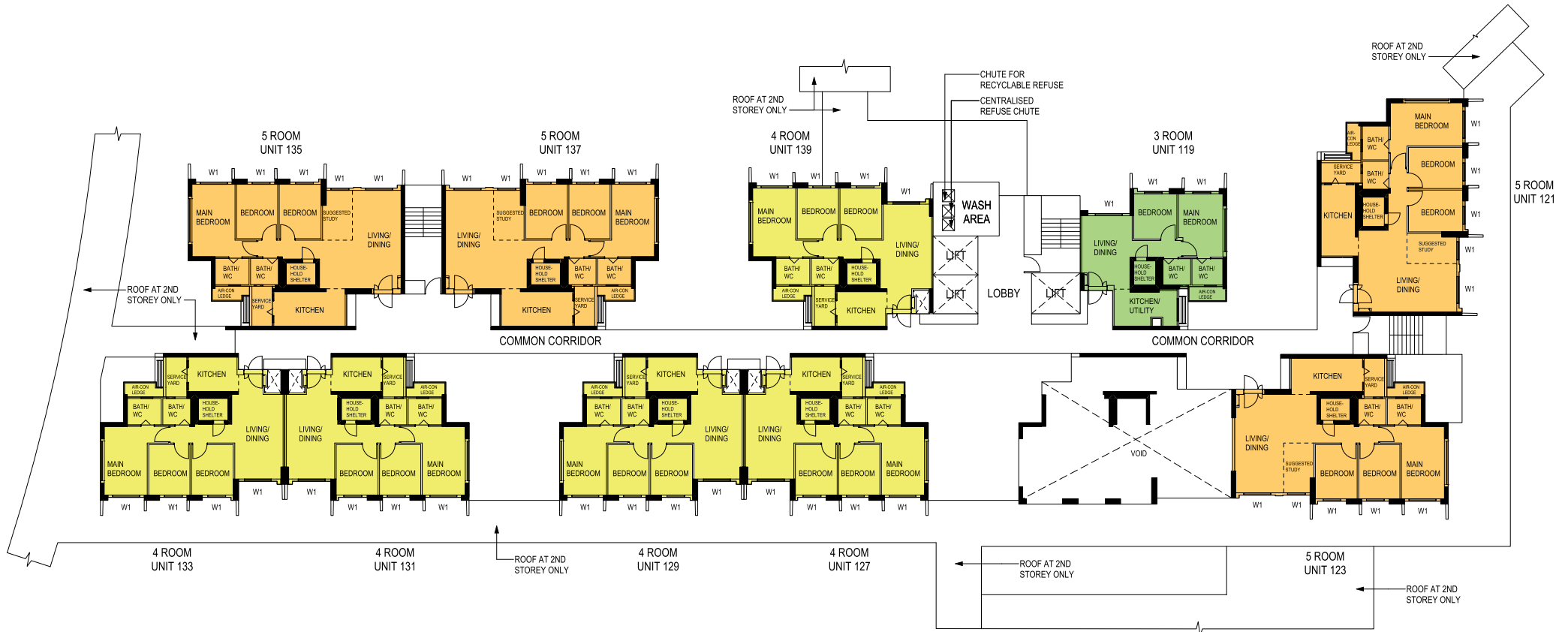

BLOCK 100B | 2ND STOREY FLOOR PLAN

UNITS AT AND ABOVE 12TH STOREY ARE HIGHER THAN THE MAIN ROOF GARDEN LEVEL OF BLOCK 101

<p>WINDOW LEGEND:</p>	<p>UNLESS OTHERWISE INDICATED, ALL WINDOWS WILL BE STANDARD HEIGHT WINDOWS</p>	<p>SCALE 0 2 4 6 8 10 METRES</p>	<p>THE COLOURED FLOOR PLAN IS NOT INTENDED TO DEMARCATATE THE BOUNDARY OF THE FLAT</p>
<p>W1 - THREE QUARTER HEIGHT WINDOW (APPROX. 550mm HIGH PARAPET WALL)</p>			

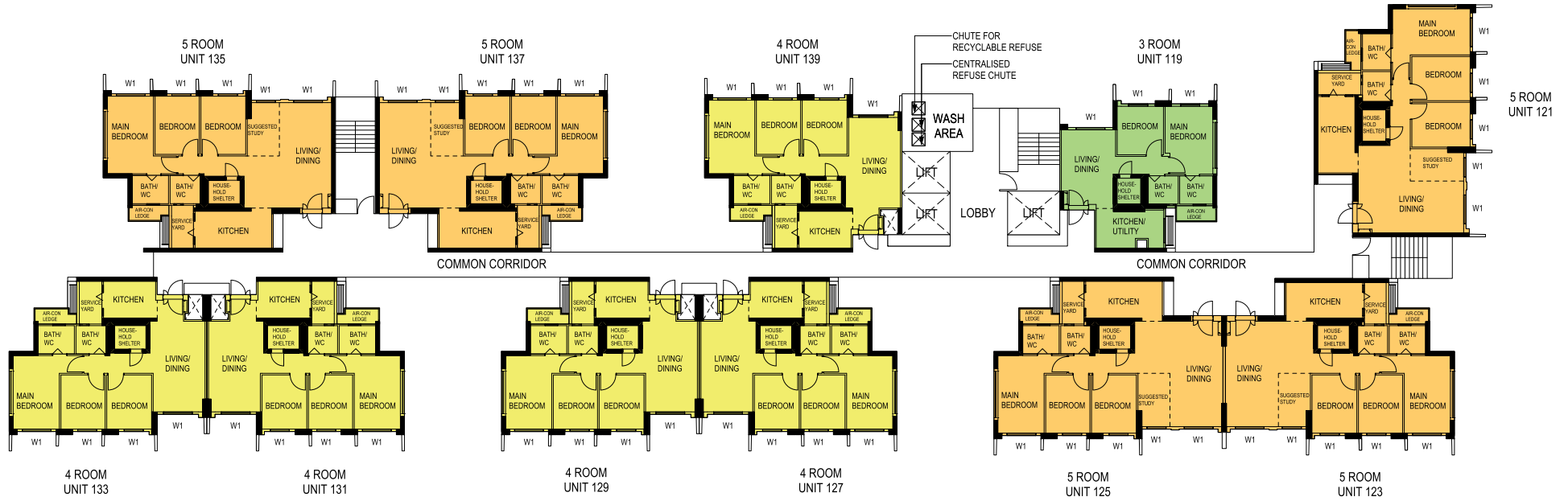

BLOCK 100B | 3RD TO 4TH, 8TH TO 10TH & 14TH TO 16TH STOREY FLOOR PLAN

UNITS AT AND ABOVE 12TH STOREY ARE HIGHER THAN THE MAIN ROOF GARDEN LEVEL OF BLOCK 101

<p>WINDOW LEGEND:</p>	<p>UNLESS OTHERWISE INDICATED, ALL WINDOWS WILL BE STANDARD HEIGHT WINDOWS</p>	<p>SCALE 0 2 4 6 8 10 METRES</p>	<p>THE COLOURED FLOOR PLAN IS NOT INTENDED TO DEMARCATATE THE BOUNDARY OF THE FLAT</p>
<p>W1 - THREE QUARTER HEIGHT WINDOW (APPROX. 550mm HIGH PARAPET WALL)</p>			

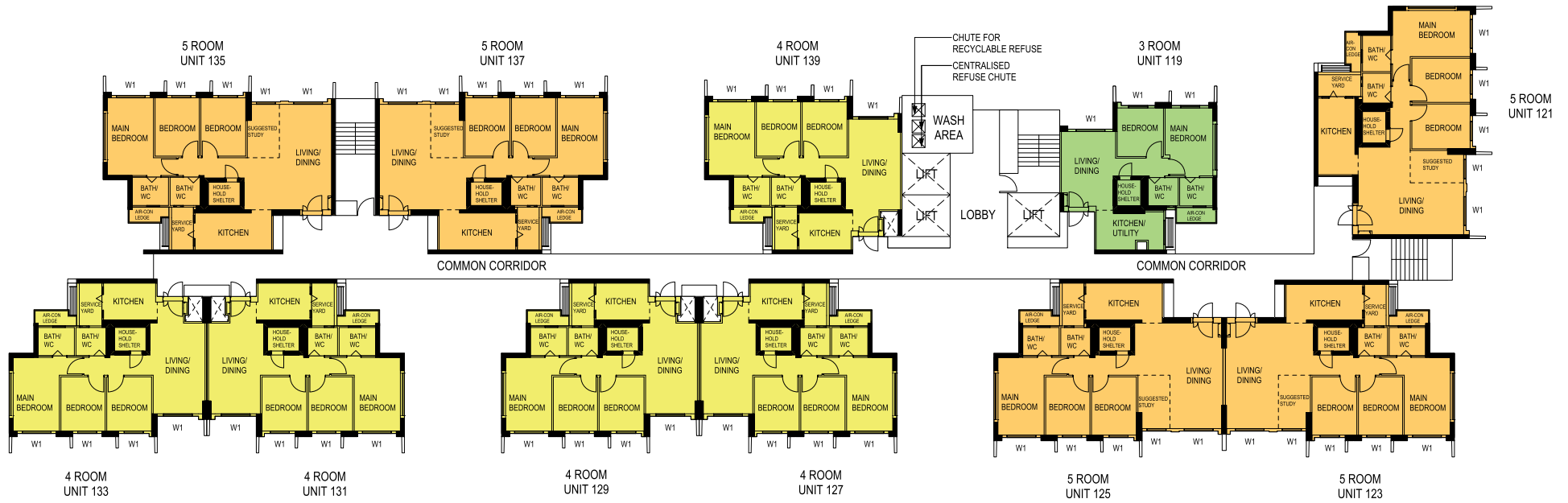

BLOCK 100B | 5TH TO 7TH, 11TH TO 13TH, 17TH & 18TH STOREY FLOOR PLAN

UNITS AT AND ABOVE 12TH STOREY ARE HIGHER THAN THE MAIN ROOF GARDEN LEVEL OF BLOCK 101

<p>WINDOW LEGEND:</p>	<p>UNLESS OTHERWISE INDICATED, ALL WINDOWS WILL BE STANDARD HEIGHT WINDOWS</p>	<p>SCALE 0 2 4 6 8 10 METRES</p>	<p>THE COLOURED FLOOR PLAN IS NOT INTENDED TO DEMARCATATE THE BOUNDARY OF THE FLAT</p>
<p>W1 - THREE QUARTER HEIGHT WINDOW (APPROX. 550mm HIGH PARAPET WALL)</p>			



BLOCK 101A | 2ND TO 4TH, 8TH TO 10TH & 14TH STOREY FLOOR PLAN

UNITS AT AND ABOVE 12TH STOREY ARE HIGHER THAN THE MAIN ROOF GARDEN LEVEL OF BLOCK 101

<p>WINDOW LEGEND:</p>	<p>UNLESS OTHERWISE INDICATED, ALL WINDOWS WILL BE STANDARD HEIGHT WINDOWS</p>	<p>SCALE 0 2 4 6 8 10 METRES</p>	<p>THE COLOURED FLOOR PLAN IS NOT INTENDED TO DEMARCATATE THE BOUNDARY OF THE FLAT</p>
<p>W1 - THREE QUARTER HEIGHT WINDOW (APPROX. 550mm HIGH PARAPET WALL)</p>			



BLOCK 101A | 5TH TO 7TH & 11TH TO 13TH STOREY FLOOR PLAN

UNITS AT AND ABOVE 12TH STOREY ARE HIGHER THAN THE MAIN ROOF GARDEN LEVEL OF BLOCK 101

<p>WINDOW LEGEND:</p>	<p>UNLESS OTHERWISE INDICATED, ALL WINDOWS WILL BE STANDARD HEIGHT WINDOWS</p>	<p>SCALE 0 2 4 6 8 10 METRES</p>	<p>THE COLOURED FLOOR PLAN IS NOT INTENDED TO DEMARCATATE THE BOUNDARY OF THE FLAT</p>
<p>W1 - THREE QUARTER HEIGHT WINDOW (APPROX. 550mm HIGH PARAPET WALL)</p>			



BLOCK 101B | 2ND TO 4TH, 8TH TO 10TH & 14TH STOREY FLOOR PLAN

UNITS AT AND ABOVE 12TH STOREY ARE HIGHER THAN THE MAIN ROOF GARDEN LEVEL OF BLOCK 101

<p>WINDOW LEGEND:</p>	<p>UNLESS OTHERWISE INDICATED, ALL WINDOWS WILL BE STANDARD HEIGHT WINDOWS</p>	<p>SCALE 0 2 4 6 8 10 METRES</p>	<p>THE COLOURED FLOOR PLAN IS NOT INTENDED TO DEMARCATATE THE BOUNDARY OF THE FLAT</p>
<p>W1 - THREE QUARTER HEIGHT WINDOW (APPROX. 550mm HIGH PARAPET WALL)</p>			



BLOCK 101B | 5TH TO 7TH & 11TH TO 13TH STOREY FLOOR PLAN

UNITS AT AND ABOVE 12TH STOREY ARE HIGHER THAN THE MAIN ROOF GARDEN LEVEL OF BLOCK 101

<p>WINDOW LEGEND:</p>	<p>UNLESS OTHERWISE INDICATED, ALL WINDOWS WILL BE STANDARD HEIGHT WINDOWS</p>	<p>SCALE 0 2 4 6 8 10 METRES</p>	<p>THE COLOURED FLOOR PLAN IS NOT INTENDED TO DEMARCATATE THE BOUNDARY OF THE FLAT</p>
<p>W1 - THREE QUARTER HEIGHT WINDOW (APPROX. 550mm HIGH PARAPET WALL)</p>			

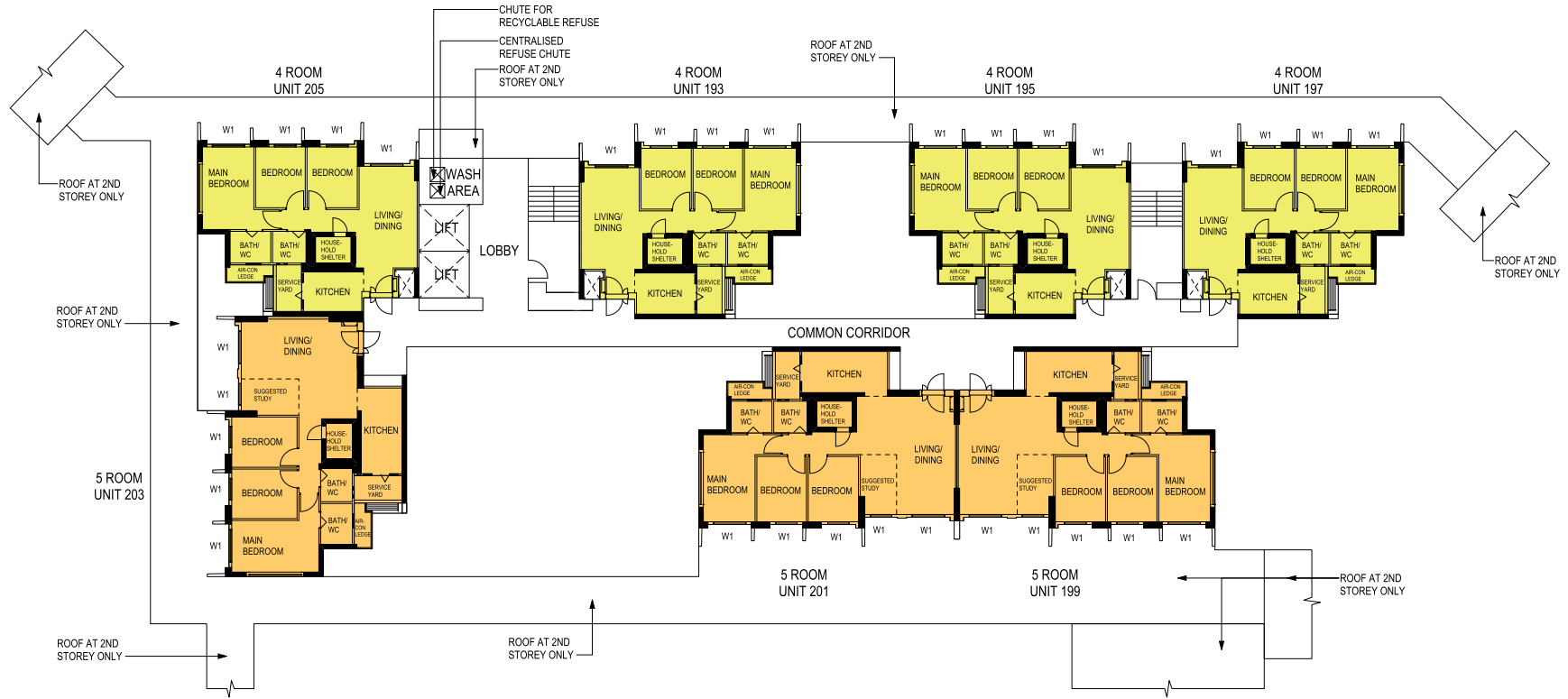

BLOCK 102A | 2ND TO 4TH, 8TH TO 10TH, 14TH & 15TH STOREY FLOOR PLAN

UNITS AT AND ABOVE 12TH STOREY ARE HIGHER THAN THE MAIN ROOF GARDEN LEVEL OF BLOCK 101

<p>WINDOW LEGEND:</p>	<p>UNLESS OTHERWISE INDICATED, ALL WINDOWS WILL BE STANDARD HEIGHT WINDOWS</p>	<p>SCALE 0 2 4 6 8 10 METRES</p>	<p>THE COLOURED FLOOR PLAN IS NOT INTENDED TO DEMARCATATE THE BOUNDARY OF THE FLAT</p>
<p>W1 - THREE QUARTER HEIGHT WINDOW (APPROX. 550mm HIGH PARAPET WALL)</p>			



BLOCK 102A | 5TH TO 7TH & 11TH TO 13TH STOREY FLOOR PLAN

UNITS AT AND ABOVE 12TH STOREY ARE HIGHER THAN THE MAIN ROOF GARDEN LEVEL OF BLOCK 101

<p>WINDOW LEGEND:</p>	<p>UNLESS OTHERWISE INDICATED, ALL WINDOWS WILL BE STANDARD HEIGHT WINDOWS</p>	<p>SCALE 0 2 4 6 8 10 METRES</p>	<p>THE COLOURED FLOOR PLAN IS NOT INTENDED TO DEMARCATATE THE BOUNDARY OF THE FLAT</p>
<p>W1 - THREE QUARTER HEIGHT WINDOW (APPROX. 550mm HIGH PARAPET WALL)</p>			



BLOCK 102B | 2ND TO 4TH, 8TH TO 10TH, 14TH & 15TH STOREY FLOOR PLAN

UNITS AT AND ABOVE 12TH STOREY ARE HIGHER THAN THE MAIN ROOF GARDEN LEVEL OF BLOCK 101

<p>WINDOW LEGEND:</p>	<p>UNLESS OTHERWISE INDICATED, ALL WINDOWS WILL BE STANDARD HEIGHT WINDOWS</p>	<p>SCALE 0 2 4 6 8 10 METRES</p>	<p>THE COLOURED FLOOR PLAN IS NOT INTENDED TO DEMARCATATE THE BOUNDARY OF THE FLAT</p>
<p>W1 - THREE QUARTER HEIGHT WINDOW (APPROX. 550mm HIGH PARAPET WALL)</p>			



BLOCK 102B | 5TH TO 7TH & 11TH TO 13TH STOREY FLOOR PLAN

UNITS AT AND ABOVE 12TH STOREY ARE HIGHER THAN THE MAIN ROOF GARDEN LEVEL OF BLOCK 101

<p>WINDOW LEGEND:</p>	<p>UNLESS OTHERWISE INDICATED, ALL WINDOWS WILL BE STANDARD HEIGHT WINDOWS</p>	<p>SCALE 0 2 4 6 8 10 METRES</p>	<p>THE COLOURED FLOOR PLAN IS NOT INTENDED TO DEMARCATATE THE BOUNDARY OF THE FLAT</p>
<p>W1 - THREE QUARTER HEIGHT WINDOW (APPROX. 550mm HIGH PARAPET WALL)</p>			



BLOCK 102C | 2ND TO 4TH, 8TH TO 10TH, 14TH & 15TH STOREY FLOOR PLAN

<p>WINDOW LEGEND:</p>	<p>UNLESS OTHERWISE INDICATED, ALL WINDOWS WILL BE STANDARD HEIGHT WINDOWS</p>	<p>SCALE 0 2 4 6 8 10 METRES</p>	<p>THE COLOURED FLOOR PLAN IS NOT INTENDED TO DEMARCATATE THE BOUNDARY OF THE FLAT</p>
<p>W1 - THREE QUARTER HEIGHT WINDOW (APPROX. 550mm HIGH PARAPET WALL)</p>			

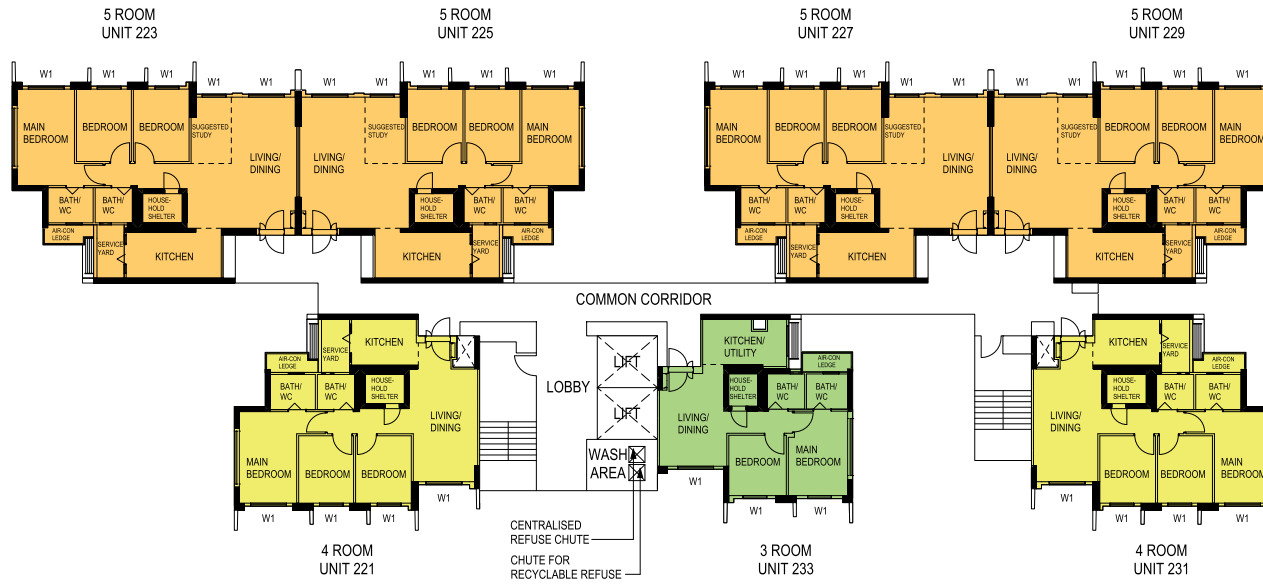

BLOCK 102C | 5TH TO 7TH & 11TH TO 13TH STOREY FLOOR PLAN

<p>WINDOW LEGEND:</p>	<p>UNLESS OTHERWISE INDICATED, ALL WINDOWS WILL BE STANDARD HEIGHT WINDOWS</p>		
<p>W1 - THREE QUARTER HEIGHT WINDOW (APPROX. 550mm HIGH PARAPET WALL)</p>		<p>SCALE 0 2 4 6 8 10 METRES</p>	<p>THE COLOURED FLOOR PLAN IS NOT INTENDED TO DEMARCATATE THE BOUNDARY OF THE FLAT</p>

GENERAL SPECIFICATIONS FOR PLANTATION VERGE

For 2-room Flexi (short lease)

Foundation

Piled foundations.

Structure

Reinforced concrete structural framework with reinforced concrete slabs.

Roof

Reinforced concrete roof slab with precast concrete secondary roofing.

Walls

All external and internal walls are constructed with reinforced concrete/ precast panels/ drywall partition system/ precast lightweight concrete partitions.

Windows

Aluminium framed windows with tinted glass.

Doors

Entrance	: laminated timber door and metal gate
Bedroom	: laminated UPVC sliding partition/ door, where applicable
Bathroom/ WC	: laminated UPVC folding door
Household Shelter	: metal door
Living/ Dining	: laminated UPVC folding door (optional)

Finishes

Living/ Dining/ Bedroom Floor	: vinyl strip flooring with laminated UPVC skirting
Kitchen/ Bathroom/ WC/ Household Shelter Floor	: glazed porcelain tiles
Kitchen/ Bathroom/ WC Walls	: glazed porcelain tiles
Ceilings/ Other Walls	: skim coated or plastered and painted

Fittings

Quality Locksets
 Water Closet Suite
 Clothes Drying Rack
 Grab Bars
 Wash basin with tap mixer, bath/ shower mixer with shower set
 Built-in kitchen cabinets with induction hob and cooker hood, kitchen sink and dish drying rack (optional)
 Built-in Wardrobe (optional)
 Window Grilles (optional)
 Water Heater (optional)
 Lighting (optional)

Services

Gas services and concealed water supply pipes
 Exposed sanitary stacks at Air-con ledge
 Concealed electrical wiring to lighting and power points (including water heater and air-conditioning points)
 Television points
 Data points

Important Notes

- 1) The Household Shelter is designed for use as civil defence shelter. The walls, ceiling, floor and door of the Household Shelter shall not be hacked, drilled, altered or removed.
- 2) Laminated UPVC door frame shall be provided to all Bedroom and Bathroom/ WC door openings.
- 3) Any unused or unoccupied open spaces in front of or nearby/ adjacent to the flat units are not available for purchase and the HDB will not entertain any request from the flat owners to purchase and/ or enclose the unused or unoccupied open spaces.
- 4) The details of services in a flat, e.g. gas pipes, water pipes, sanitary stacks, electrical wiring, television points, data points, etc. are not indicated on the plans.

You are advised to visit HDB's website at www.hdb.gov.sg for information on renovation rules.

GENERAL SPECIFICATIONS FOR PLANTATION VERGE

For 2-Room Flexi, 3-Room, 4-Room, 5-Room

Foundation

Piled foundations.

Structure

Reinforced concrete structural framework with reinforced concrete slabs.

Roof

Reinforced concrete roof slab with precast concrete secondary roofing.

Walls

All external and internal walls are constructed with reinforced concrete/ precast panels/ drywall partition system/ precast lightweight concrete partitions.

Windows

Aluminium framed windows with tinted glass.

Doors

Entrance	: laminated timber door and metal gate
Bedroom	: laminated UPVC door
	: laminated UPVC sliding partition/ door for 2-room Flexi, where applicable
Bathroom/ WC	: laminated UPVC folding door
Household Shelter	: metal door
Service Yard	: aluminium framed door with glass

Finishes

Living/ Dining/ Bedroom Floor	: vinyl strip flooring with laminated UPVC skirting
Kitchen/ Utility/ Bathroom/ WC/ Household Shelter Floor	: glazed porcelain tiles
Service Yard Floor	: glazes porcelain tiles with tile skirting
Kitchen/ Bathroom/ WC Walls	: glazed porcelain tiles
Ceilings/ Other Walls	: skim coated or plastered and painted

Fittings

Quality Locksets
Water Closet Suite
Clothes Drying Rack
Wash basin with tap mixer, bath/ shower mixer with shower set

Services

Gas services and concealed water supply pipes
Exposed sanitary stacks (which can be located at Service Yard and/ or Air-con ledge)
Concealed electrical wiring to lighting and power points (including water heater and air-conditioning points)
Television points
Data points

Important Notes

- 1) The Household Shelter is designed for use as civil defence shelter. The walls, ceiling, floor and door of the Household Shelter shall not be hacked, drilled, altered or removed.
- 2) Laminated UPVC door frame shall be provided to all Bathroom/ WC door openings.
- 3) Any unused or unoccupied open spaces in front of or nearby/ adjacent to the flat units are not available for purchase and the HDB will not entertain any request from the flat owners to purchase and/ or enclose the unused or unoccupied open spaces.
- 4) The details of services in a flat, e.g. gas pipes, water pipes, sanitary stacks, electrical wiring, television points, data points, etc. are not indicated on the plans.

You are advised to visit HDB's website at www.hdb.gov.sg for information on renovation rules.

DISCLAIMER

- 1) HDB owns the copyright in all information, maps, and plans of this brochure.
- 2) The content provided in this brochure is not intended to form part of any offer or contract for the sale of flats. They are provided for your general information only and are not statements or representations of fact.
- 3) Visual representations such as pictures, art renderings, depictions, illustrations, photographs, drawings, as well as other graphic representations and references are only artistic impressions. They are provided for your general information only, and are not representations of fact.
- 4) The information on this project, including but not limited to the dimensions, areas, plans, colour schemes, descriptions, and specifications, are subject to change or review without notice at our sole discretion or if required by the relevant authorities.
- 5) We may at any time, without any notice and at our sole discretion, change any aspect of this project, including but not limited to the omission, amalgamation, increase, or reduction of amenities and facilities, colour schemes, design features, and specifications.
- 6) We will not entertain any request for alteration of the layout or specifications of a flat to suit individual needs.
- 7) While reasonable care has been taken in providing the information in this brochure, we do not warrant its accuracy. We shall not be responsible in any way for any damage or loss suffered by any person whether directly or indirectly as a result of reliance on the said information or as a result of any error or omission therein.
- 8) The floor areas shown are scaled strata areas and are subject to final survey.
- 9) The surrounding land use, proposed facilities and their locations as shown in the maps and plans are indicative only and subject to change. They may include ancillary uses allowed under the Urban Redevelopment Authority's prevailing Development Control guidelines. Housing projects may be located near roads, railways, airbases, and land used for non-residential purposes and hence, residents may experience higher noise levels.
- 10) We reserve the right to use or allow the use of any:
 - Void deck of any apartment block
 - Car park;
 - Common property (such as precinct pavilion); or
 - Standalone community building,for:
 - Future amenities/ facilities (such as child care centres, eldercare facilities, education centres, residents' network centres, and day activity centres);
 - Commercial facilities (such as shops and eating houses);
 - Mechanical and electrical rooms; and
 - Such other facilities as we deem fit.
- 11) This brochure does not and is not intended to provide full and complete information of the guidelines or requirements of the relevant authorities. You are advised to approach the relevant authorities directly for full information and details of these guidelines and requirements.

OPTIONAL COMPONENT SCHEME

(2-room Flexi Flats in projects constructed using the Prefabricated Prefinished Volumetric Construction method)

The Optional Component Scheme (OCS) provides convenience for flat buyers, and is offered on an opt-in basis. Choose the OCS items you want before your flat selection appointment.

The cost of the OCS items will be added to the selling price of the selected flat.

All 2-room Flexi flats come with:

- Floor finishes in the living/ dining room, bedroom, bathroom, household shelter, and kitchen
- Wall tiles in the bathroom and kitchen
- Sliding partition/ door for bedroom, folding bathroom door
- Sanitary fittings, i.e. wash basin with tap mixer, shower set with bath/ shower mixer, and water closet suite



- Grab bars will be installed for all short-lease flats to assist elderly buyers in moving around the flats



Details on the Optional Component Scheme (OCS) package for short-lease 2-room Flexi flats are in the next page.

Disclaimer: All displays and images shown here are strictly for reference only and are subject to change without notice. The displays and images shown here are conceptual and indicative only and the colour schemes, design, dimensions, type, tonal differences and specifications may differ from the actual fittings installed in the flat.

OPTIONAL COMPONENT SCHEME

(2-room Flexi Flats in projects constructed using the Prefabricated Prefinished Volumetric Construction method)

FOR SHORT-LEASE 2-ROOM FLEXI FLATS ONLY

Elderly buyers of short-lease 2-room Flexi flats who wish to enjoy the convenience of having a flat in move-in condition can opt in for the following:

ELDERLY-FRIENDLY FITTINGS



- Built-in kitchen cabinets with induction hob and cooker hood, kitchen sink, tap and dish drying rack.



Here are some features of an induction hob:

- It does not produce an open flame
- Its cooking zone cools down faster
- It is easier to clean than a gas hob
- As it has a flat surface, pots placed on an induction hob are less likely to topple over.

With these features, the use of the induction hob would promote a safer and cleaner environment.

- An option to have a lower counter top height

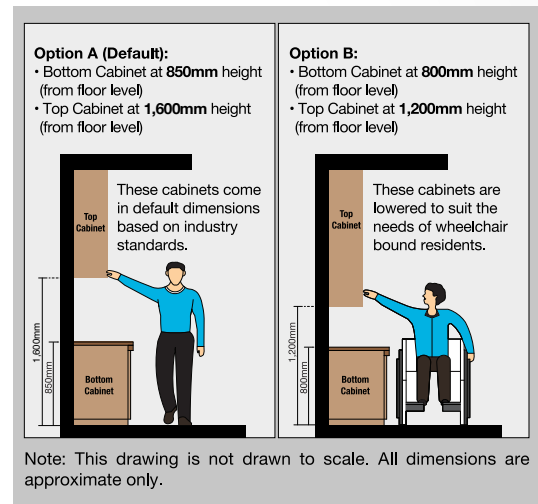

- Kitchen cabinets come with mobile cabinets to provide knee space (especially for wheelchair users)
- Built-in bedroom wardrobe with a lower clothes hanging rod for easy reach

- Folding door at the flexible space in the 2-room Flexi (Type 2) flats



OTHER FITTINGS



- Window grilles for safety and security



- Mirror



- Toilet roll holder



- Lighting



- Water heater

The cost of this OCS package will be added to the selling price of the selected flat.

Disclaimer: All displays and images shown here are strictly for reference only and are subject to change without notice. The displays and images shown here are conceptual and indicative only and the colour schemes, design, dimensions, type, tonal differences and specifications may differ from the actual fittings installed in the flat.